

Linear Application of DeepRoot Tree Root Barriers at Time of Installing Concrete Sidewalks and Curbs

TYPICAL SECTION OF CURB AND GUTTER WITH DEEPROOT TREE ROOT BARRIER INSET INTO CONCRETE. BARRIER INSTALLED IN A TRENCH IN SUBGRADE WHICH IS THEN COMPACTED. BARRIER IS SET SO THAT TOP EDGE WILL BE 2" (5CM) BELOW FINISH GRADE OF CURB, AND SET FLUSH WITH EDGE OF CURB. BARRIER RIBS FACE TOWARD TREE ROOTS.

INSTALLATION SEQUENCE:

1. Prepare base and subgrade.
2. Trench to appropriate depth for installation of root barrier so that top of barrier is 2" (5cm) below finish grade of top of curb.
3. Place root barrier in trench, vertical ribs must face toward tree roots.
4. Backfill and compact to requirements.
5. Place form material against barrier (it may be nailed from the outside of the form).

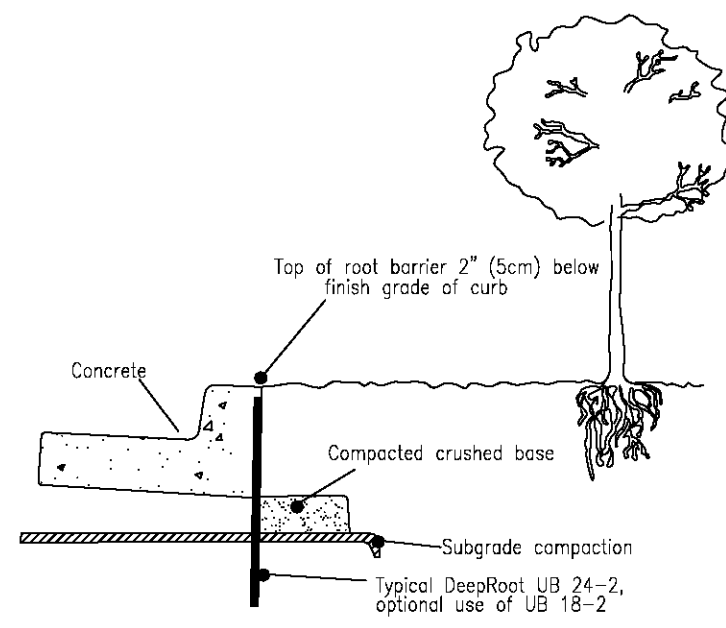

TYPICAL SECTION OF CURB, GUTTER AND SIDEWALK WITH DEEPROOT TREE ROOT BARRIER INSET INTO CONCRETE

BARRIER INSTALLED IN A TRENCH IN SUBGRADE WHICH IS THEN COMPACTED. BARRIER IS SET SO THAT TOP EDGE WILL BE 2" (5CM) ABOVE COMPACTED BASE (or halfway between base and finish grade of SW). BARRIER RIBS FACE TOWARD TREE ROOTS.

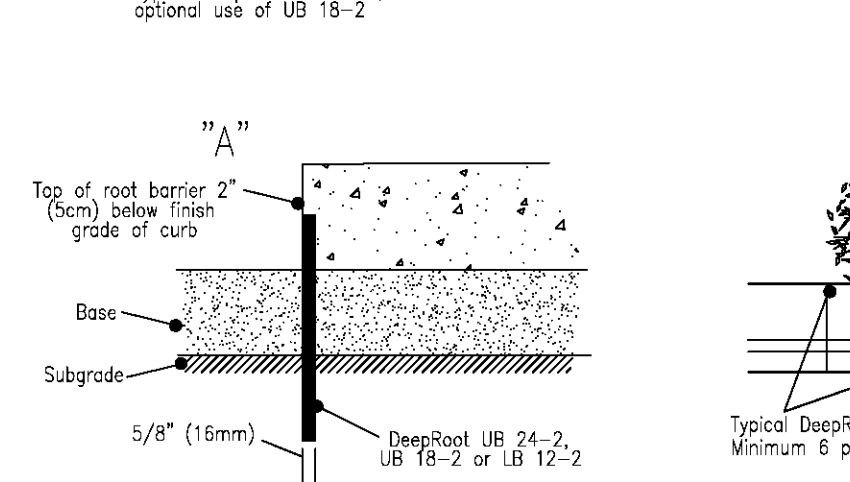
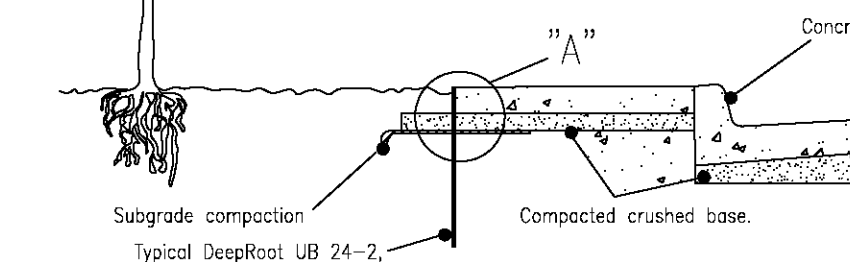

INSTALLATION SEQUENCE:

1. Prepare base and subgrade.
2. Trench to appropriate depth for installation of root barrier so that top of barrier is 2" (5cm) below finish grade of top of sidewalk (or halfway between top of compacted base and finish grade of SW).
3. Place root barrier in trench, vertical ribs must face toward tree roots.
4. Backfill and compact to requirements.
5. Place form material against barrier (it may be nailed from the outside of the form).

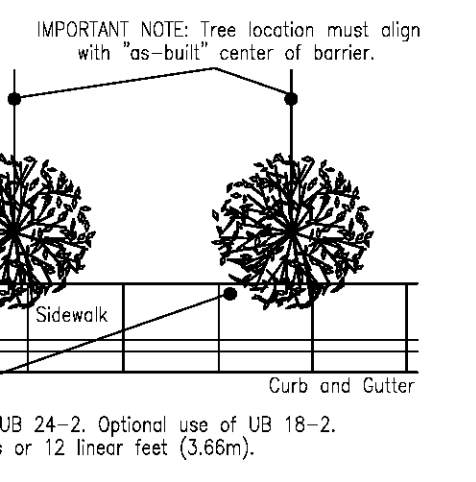

Linear Style Planting with DeepRoot Barriers

Determine the correct number of panels to be used. Depending upon the actual planting plan and the number of trees involved the length of linear barrier will vary, but as a general rule of thumb take the anticipated mature canopy diameter of the tree and add 2 feet (61cm). This will be the number of feet necessary for a Linear style planting application. (See chart below.)

A. Choose the barrier that best suits the application. Generally if a sidewalk, patio or driveway is to be protected, UB 18-2 is sufficient depth with 12" (30cm) UB 18-2 is an alternate choice for non-aggressive, deeper rooting trees. However for curb and gutter protection or more aggressive roots 24" (61cm) UB 24-2 is generally the better choice.

B. Dig the trench to the depth based upon the particular barrier chosen.

C. Next place the barrier in the trench with the vertical ribs facing toward the tree and align in a straight fashion. It is helpful to place the barrier against the hardscape. Use the hardscape as a guide and backfill against the barriers to promote a clean smooth fit to the hardscape. Be sure to keep the barrier's double top edge at least 1/2" (13mm) above grade to ensure roots do not grow over the top.

For a simple formula to determine the quantity of panels required for a Linear application use:
Estimated Diameter of the Tree Canopy at Maturity + 2' (61cm) = Length of Barrier per Side.

For One Side of Tree

| Expected Tree Canopy at Maturity | Feet of Barrier | Number of Panels |
|---|-----------------|------------------|
| 12' (3.6m) Dia. +2' (61cm) = 14' (4.2m) | 14' | 7 Panels |
| 18' (5.3m) Dia. +2' (61cm) = 20' (6.1m) | 20' | 10 Panels |
| 24' (7.3m) Dia. +2' (61cm) = 26' (7.9m) | 26' | 13 Panels |

Packaging:

| | |
|---------|------------------------------------|
| UB 12-2 | 40 panels (80' linear ft) / Carton |
| UB 18-2 | 26 panels (52' linear ft) / Carton |
| UB 24-2 | 20 panels (40' linear ft) / Carton |

Line can be separated at any two foot interval.

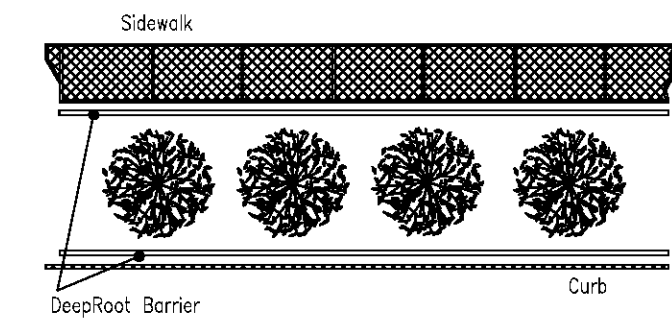

D. Plant the tree(s). The Linear style offers a more expansive rooting growth area, however adverse soil and drainage conditions may exist in the actual planting area. Take steps to ensure healthy growth of the tree at planting. Consult with a local Arborist for planting tips and recommendations.

E. If staking or guying is required we recommend using the soft, safe and economical alternative to traditional wire and hose, ArborTie (see www.deeproot.com) for details).

F. If the tree(s) will be subject to maintenance work such as lawn mowing or weed trimming we strongly recommend the installation of ArborGard+ Tree Trunk Protectors which are placed around the base of young trees to protect them from damage by weed trimmers, lawn mowers and small rodents. (See www.deeproot.com)

For additional information please visit our website at www.deeproot.com

For information regarding distributors please call: 1 800 ILV ROOT (458.7668). For help with drainage or other difficult installation questions please call DeepRoot Technical Support at: 1 800 ROOT TEK (766.8835).

As little as one side of the tree may need barrier for root direction as there may be no hardscape elsewhere requiring protection.

DeepRoot UB 12-2, UB 18-2 or UB 24-2

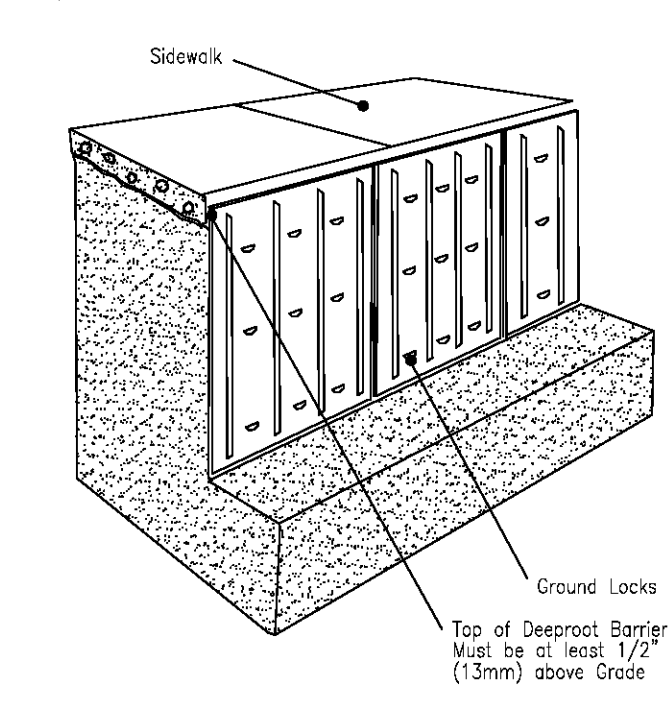

Surround Style Planting with DeepRoot Universal Barriers

When selecting the Surround style planting application you will have the greatest success by following these simple steps as illustrated below:

A. Prepare the initial planting hole as illustrated below. This is based upon the combination of desired barrier diameter and depth. Consider if drainage devices or amendments are needed to correct any adverse soil or planting conditions in the backfill area.

B. Assemble the appropriate number of DeepRoot Universal Barrier panels. The vertical root deflecting ribs on the panel must face inward, toward the root ball. (This is very important, otherwise the roots will become girdled by traveling around the smooth walled surface)

C. Next place the barrier in the center of the planting hole, keeping in mind that the double top edge of the barrier should be positioned approximately 1/2" (13mm) above grade. This helps retard potential root overgrowth. Failing to position the top edge above grade can allow root overgrowth which can lead to uprooted hardscapes.

D. Backfill and compact with soil inside the barrier to the level where the bottom of the root ball will be when positioned correctly with the crown of the root ball approximately 1" (26mm) above grade.

E. Remove the tree from its container, or cut away the top portion of burlap and position in the center of the barrier. Complete the backfill of the soil. Distribute evenly to maintain the shape of the barrier and compact the backfill every 4"-6" (10cm-15cm). Roots will die quickly if left exposed to the elements so keep exposure of the roots to a minimum.

F. If staking or guying is required we recommend using the soft, safe and economical alternative to traditional wire and hose, ArborTie (see www.deeproot.com) for details).

G. If the tree(s) will be subject to maintenance work such as lawn mowing or weed trimming we strongly recommend the installation of ArborGard+ Tree Trunk Protectors which are placed around the base of young trees to protect them from damage by weed trimmers, lawn mowers and small rodents. (See www.deeproot.com)

H. Water and follow proper tree maintenance practices.

Trees do require care and nurturing after planting. Consult with your local supplier for proper care procedures for the species you are planting. The planting instructions given here are by no means a comprehensive guide. Rather they are general guidelines to planting with DeepRoot Barriers and a survey of current planting methods. Conditions will vary however and it is recommended that an Arborist be consulted before planting.

For additional information please visit our website at www.deeproot.com

For information regarding distributors please call: 1 800 ILV ROOT (458.7668). For help with drainage or other difficult installation questions please call DeepRoot Technical Support at: 1 800 ROOT TEK (766.8835).

A Typical Surround Planting Installation Using DeepRoot Universal Barrier

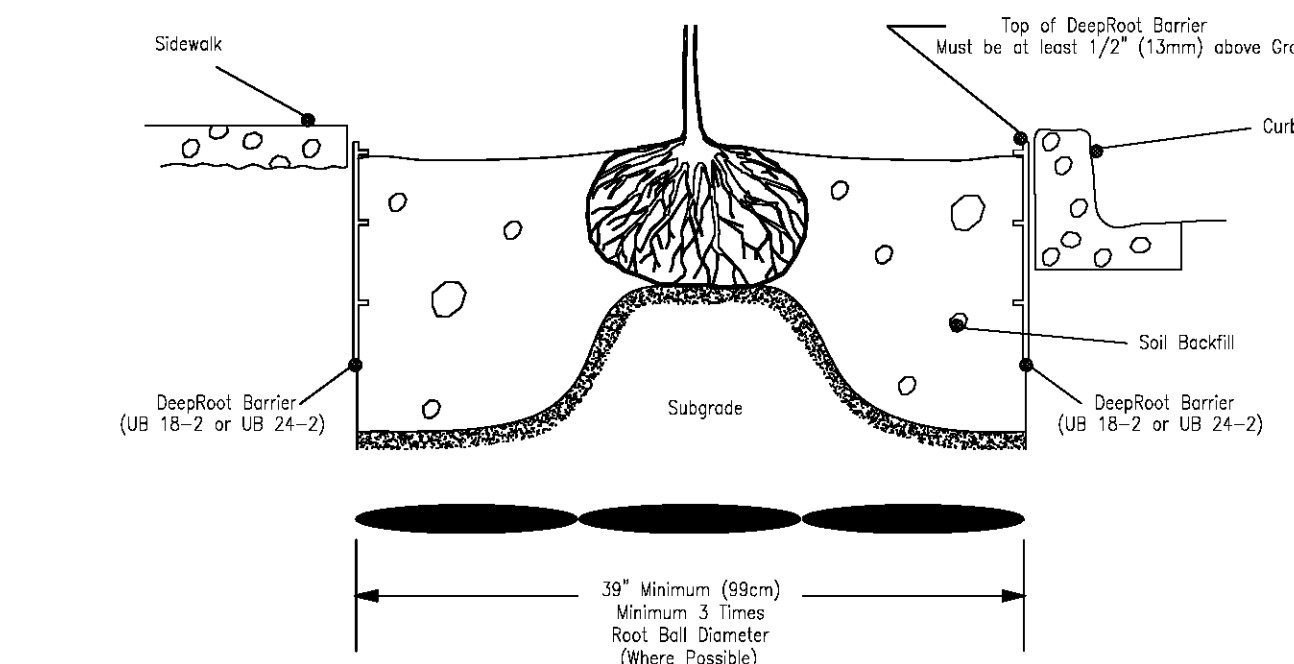

UB 24-2 Specifications 24" DeepRoot Tree Root Barriers

Specified tree root barriers are a mechanical barrier and root deflector to prevent tree roots from damaging hardscapes and landscapes. Assembled in 2' long modules to create varying sizes of openings for surrounding root balls (surround planting style) or for linear applications directly beside a hardscape adjacent to one side of the trees (Linear planting style).

A. Materials

1. The contractor shall furnish and install linear root barriers as specified. The tree root barriers shall be product # UB 24-2 as manufactured by Deep Root Partners, L.P. 81 Langton St. #4 San Francisco, CA (800-458-7668), or approved equal. The barrier shall be Black, Injection Molding Panels, of 0.085" (2.16mm) wall thickness in modules 24" (61cm) long by 24" (61 cm) deep; manufactured with a minimum 50% post consumer recycled polypropylene plastic with added ultraviolet inhibitors; recyclable. Each panel shall have:

Not less than 4 Molded Integral Vertical Root Deflecting Ribs of at least 0.085" (2.16mm) thickness protruding 1/2" (12.7mm) at 90° from interior of the barrier panel, spaced 6" (15.24cm) apart. (See panel drawing below)

A Double Top Edge consisting of two parallel, integral, horizontal ribs at the top of the panel of a minimum 0.085" (2.16mm) thickness, 3/8" (9.53mm) wide and 1/4" (6.35mm) apart with the lower rib attached to the vertical root deflecting ribs. (See Detail "A")

A minimum of 9 Anti-Lift Ground Lock Tabs consisting of integral horizontal ridges of a minimum 0.085" (2.16mm) thickness in the shape of a segment of a circle, the 2" (50.8mm) chord of the segment joining the panel wall and the segment, protruding 3/8" (9.53mm) from the panel. The nine ground locks on each panel shall be about equally spaced between each of the vertical root deflecting ribs (3 between each set of ribs, see Detail "B").

An integrated Zipper Joining System providing for instant assembly by sliding one panel into another. (See Detail "C")

2. The basic properties of the material shall be:

| Test | ASTM Test Method | Typical Value | Copolymer Polypropylene |
|-----------------------------------|------------------|---------------|-------------------------|
| Tensile strength @ yield - Wall | D638 | 2,254 | PSI |
| Tensile strength @ yield - Hinge | D638 | 2,845 | PSI |
| Tensile elongation - Wall | D638 | 7.44% | |
| Tensile elongation - Hinge | D638 | 7.01% | |
| Flexural Modulus | D790 | 115,625 | PSI |
| Notched Izod Impact - Wall | D255A | 3.84 | (ft-lb) |
| Rockwell Hardness r, scale - Wall | D785A | 84.4 | |

U.S. Patents: 5,070,642, 5,305,549 and 5,528,857. Other Patents Pending.

B. Construction and Installation

1. The contractor shall install the tree root barriers in the manner shown on the Drawings. The vertical root deflecting ribs shall be facing inward to the root ball and the double top edge shall be 1/2" (12.7mm) above grade. Each of the required number of panels shall be connected to form a circle around the root ball or joined in a linear fashion and placed along the adjacent hardscape.

2. Excavation and soil preparation shall conform to the Drawings

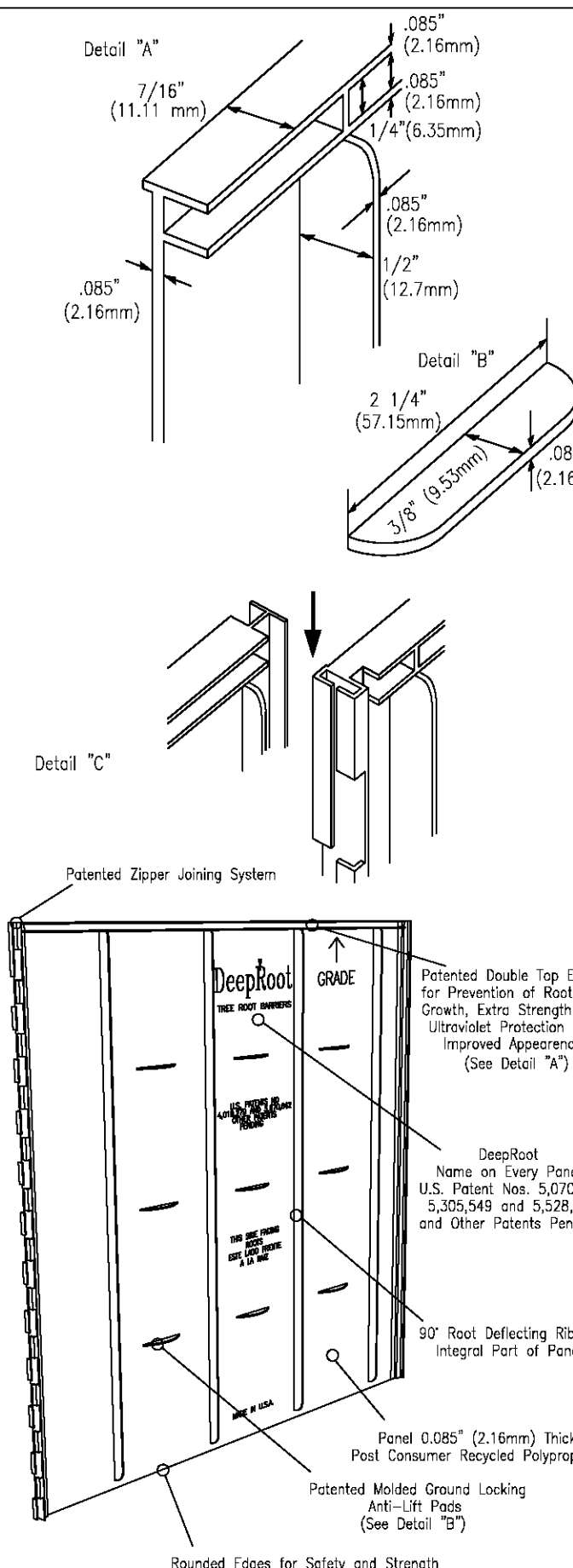

| REVISIONS | | |
|-----------|------------|-------------------------------|
| NO. | DATE | DESCRIPTION |
| 1. | 01-08-2009 | As/CDI Dev. Review Comments |
| 2. | 05-21-2009 | As/CDI Dev. Review Comments |
| 3. | 08-11-2009 | No Existing Pond Improvements |
| 4. | 11-23-2009 | As per Owner's Arch's Markup |
| 5. | 12-04-2009 | Indicate Proposed Line Posts |
| 6. | 02-03-2010 | Final Revisions as per Owner |

THIS DRAWING IS AN INSTRUMENT OF SERVICE AND THE PROPERTY OF SUNSHINE DESIGN, INC. AND SHALL REMAIN THEIR PROPERTY. THE USE OF THIS DRAWING IS RESTRICTED TO THE ORIGINAL SITE FOR WHICH IT IS PREPARED AND PUBLICATION THEREOF IS EXPRESSLY LIMITED TO SUCH USE.

Walgreen's
Normandy Blvd. and Fouraker Road
A Development by:
Rock Ventures, LLC
ROOT BARRIER NOTES & DETAILS

SUNSHINE DESIGN
Chris Commins ASLA
PMB 366 | 445-26 State Road 13 | Fruit Cove, Florida 32259
PH: 904-233-4809 Email: chris@chriscommins.com

DATE
12-05-2008
DRAWN BY
JCC / SP
SHEET NO.
LS-4