

PROJECT:

FAMILY DOLLAR

PROJECT# 401701

ADDRESS:

6384 HWY 87 N
MILTON, SANTA ROSA COUNTY,
FLORIDA

DEVELOPER:



Boos Development Group, Inc.
2651 MCGONICK DRIVE
CLEARWATER, FL 33759
TEL (727) 669-2900

CONTACT:

LORA PERSSON

ENGINEER:



foreSITE group
ForeSite Group, Inc.
5185 Peachtree Pkwy
Suite 240
Norcross, GA 30092
o 1 770 368.1399
f 1 770.368.1944
www.foresitegroupinc.com

SCALE:

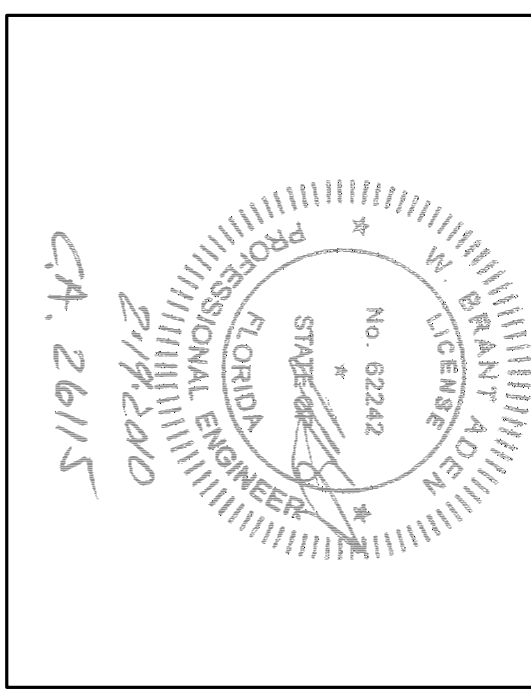

CA. 26115

REVISIONS

PER FAMILY DOLLAR	DATE
FOOT COMMENTS	10/26/09
CITY COMMENTS	11/17/09
NWE/WD COMMENTS	11/23/09
BD SET	01/28/10
	02/19/10

PROJECT MANAGER:

BLH
N.I.S.

DRAWING BY: JAM

JURISDICTION: SANTA ROSA COUNTY, FL

DATE: 05/27/09

TITLE:

PAVING DETAILS

SHEET NUMBER: C-5

SCALE: NOT TO SCALE

JOB/FILE NUMBER: 163.017

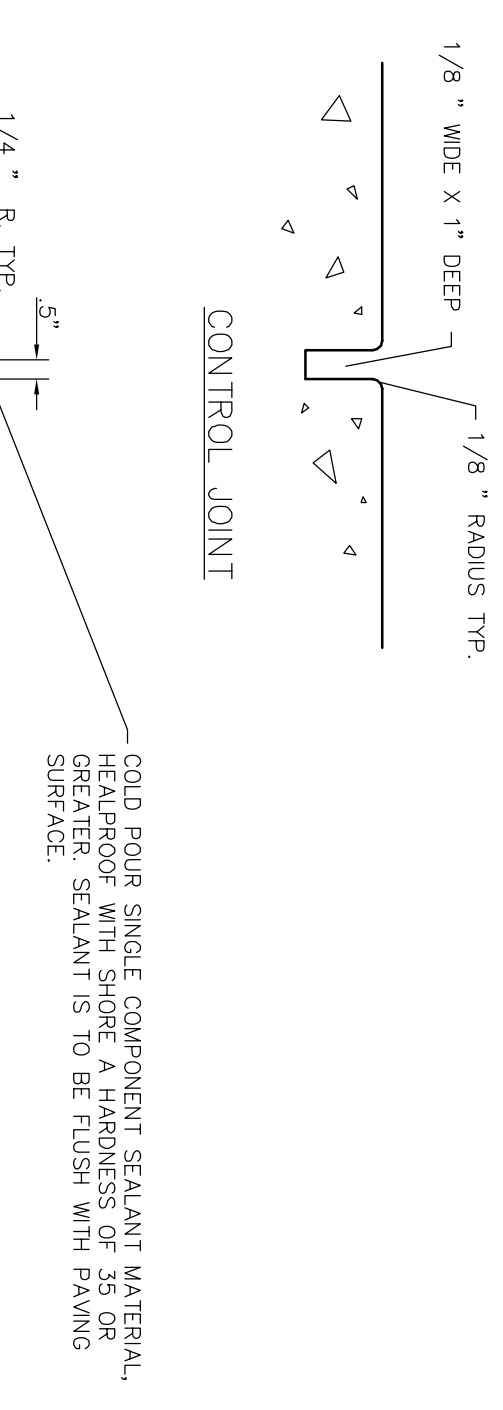

7 CONTROL AND EXPANSION JOINTS FOR SIDEWALK
NOT TO SCALE

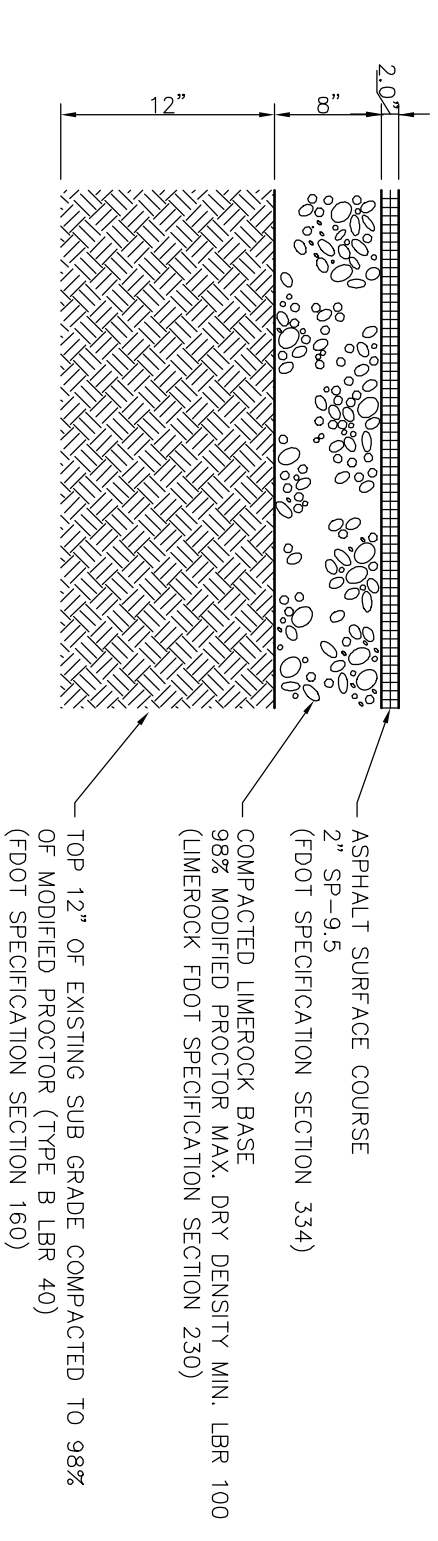

8 FDOT ASPHALT PAVING
NOT TO SCALE

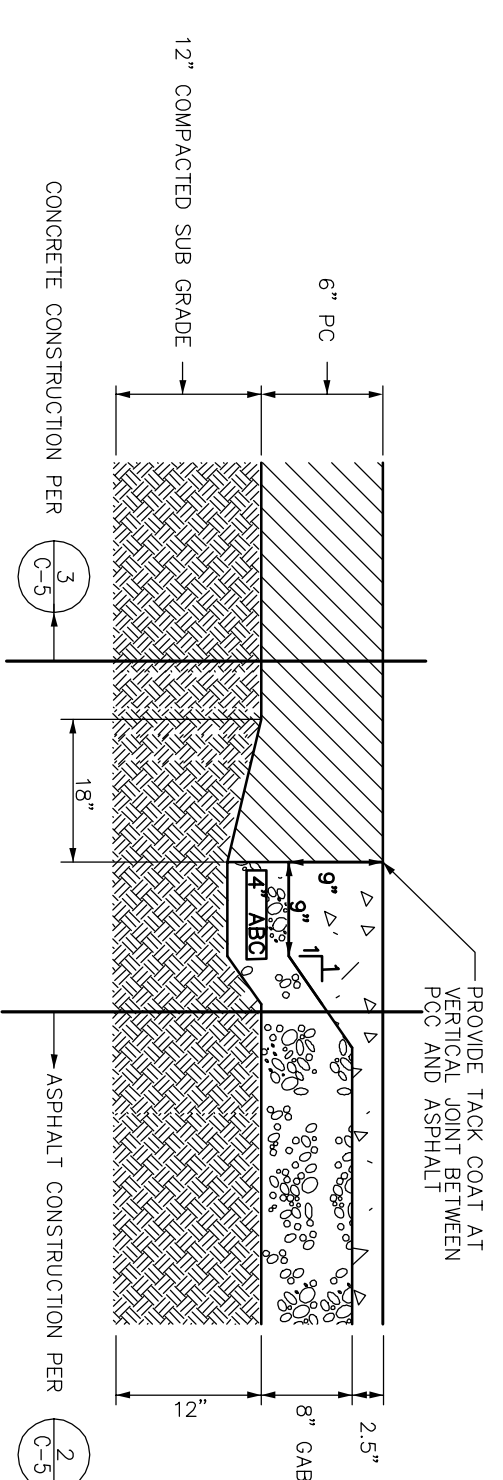

4 HEAVY DUTY CONCRETE / HEAVY DUTY ASPHALT DETAIL
NOT TO SCALE

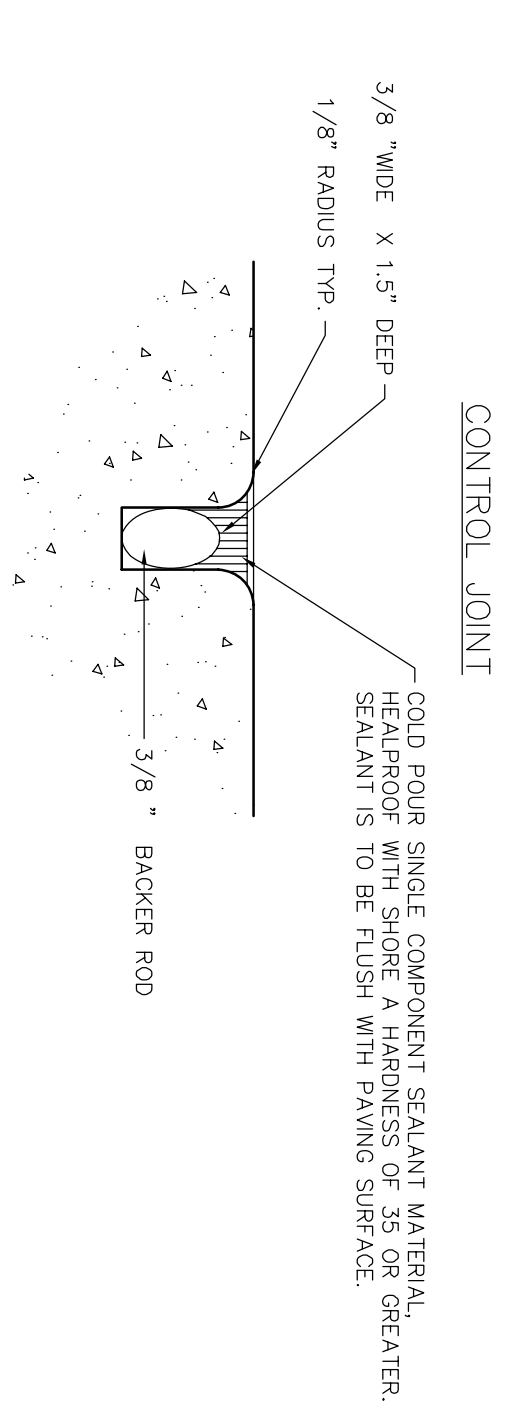

5 CONTROL JOINTS FOR HEAVY DUTY PAVEMENT
NOT TO SCALE

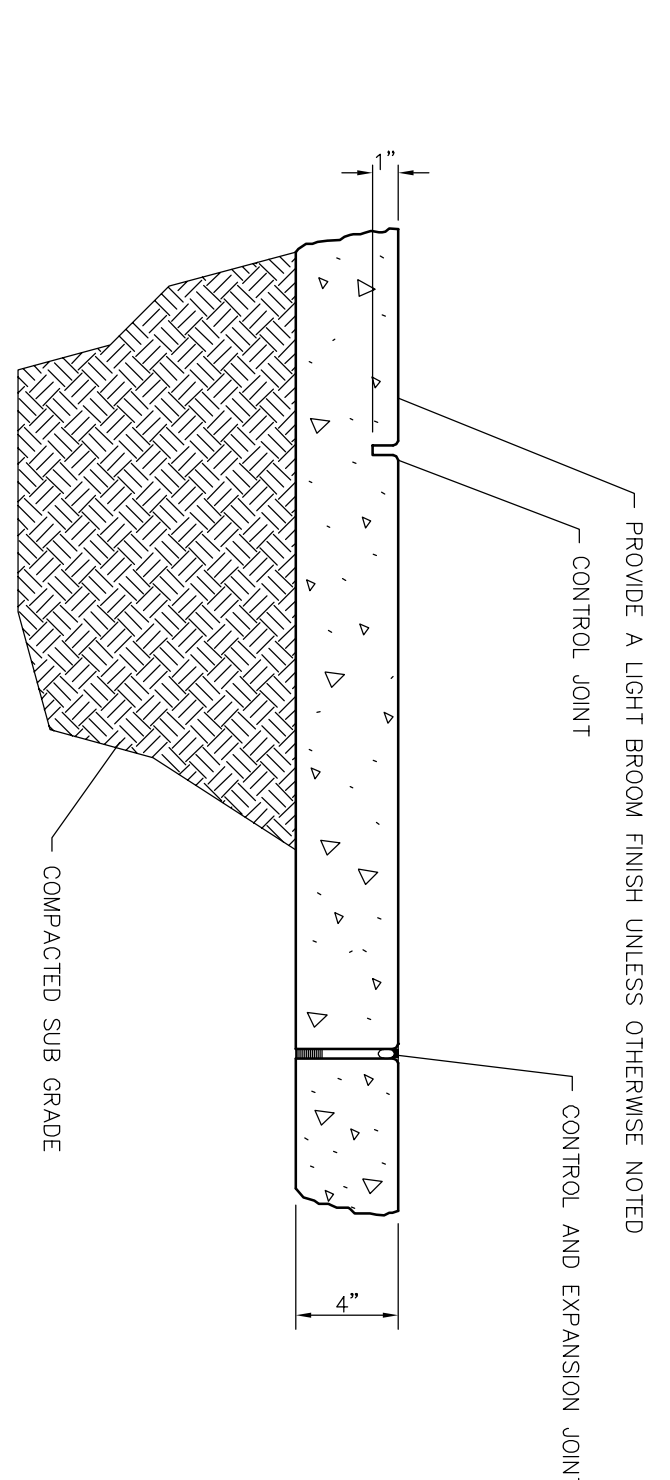

6 CONCRETE SIDEWALK DETAIL
NOT TO SCALE

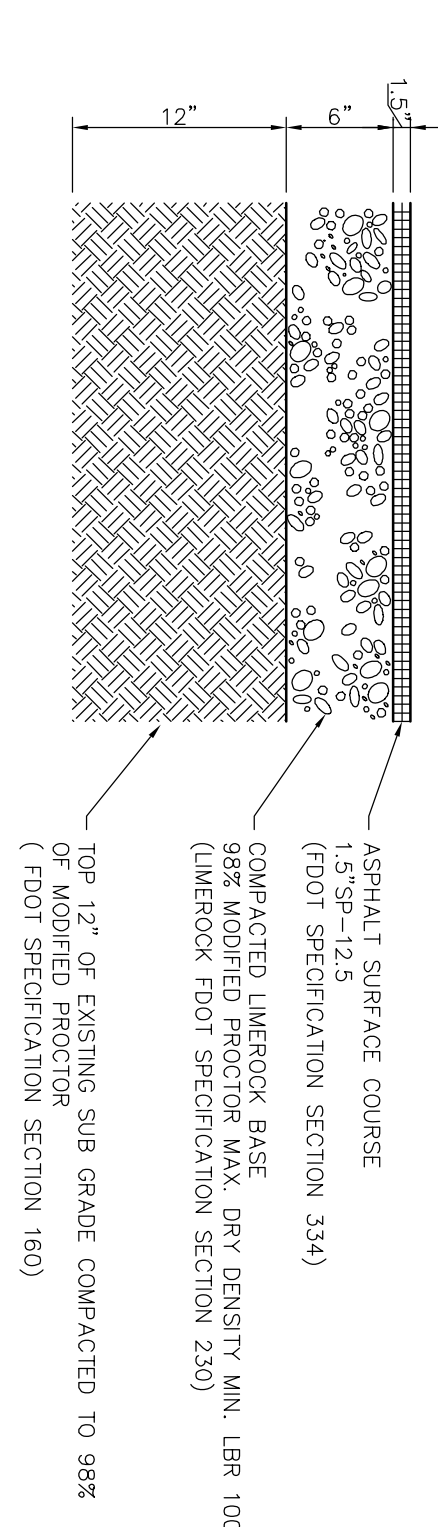

1 STANDARD DUTY ASPHALT PAVING
NOT TO SCALE

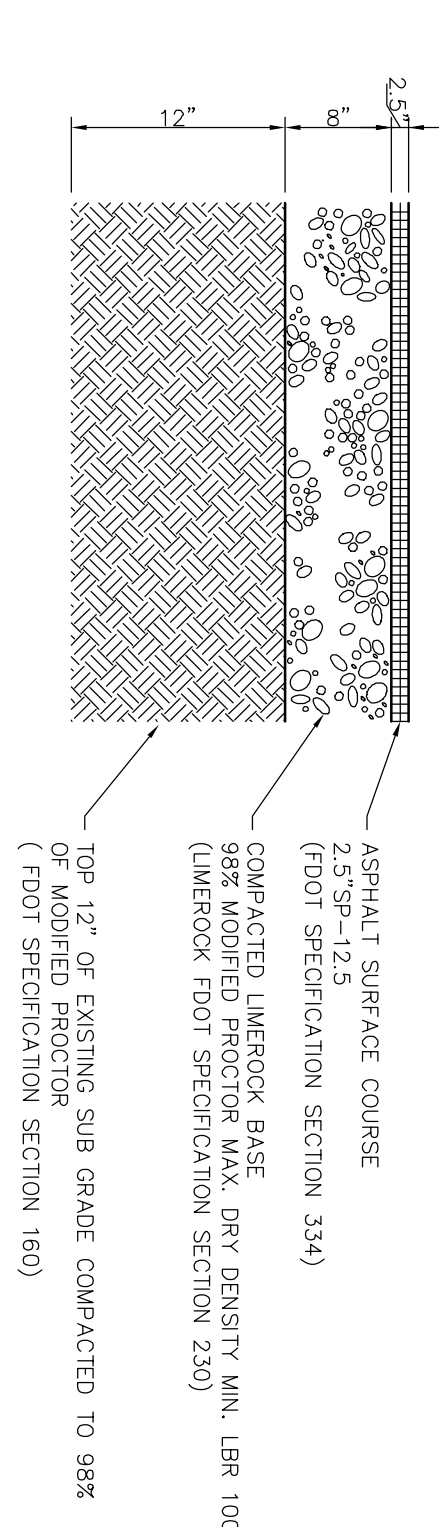

2 HEAVY DUTY ASPHALT PAVING
NOT TO SCALE

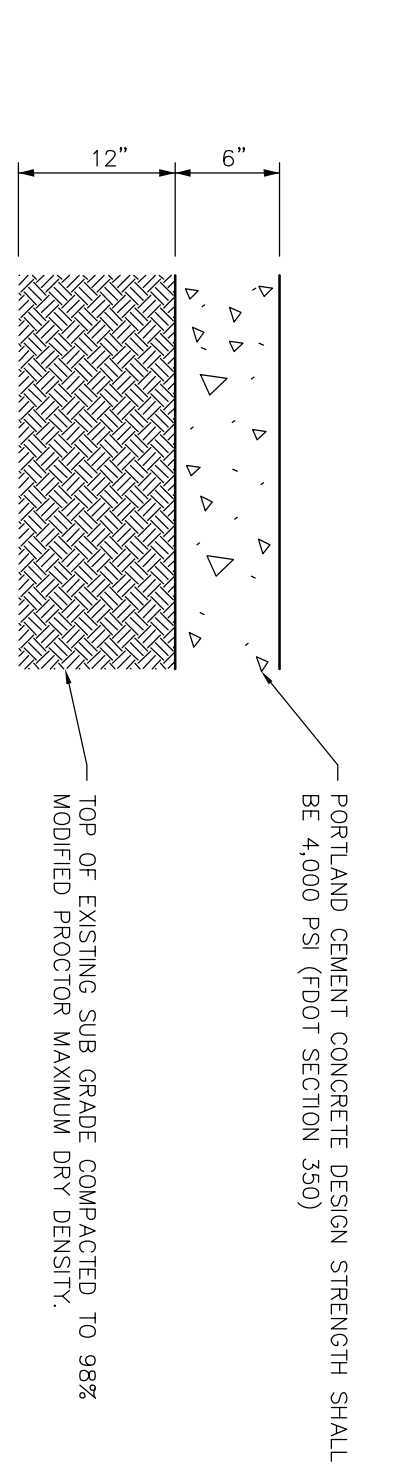

3 HEAVY DUTY CONCRETE PAVING
NOT TO SCALE

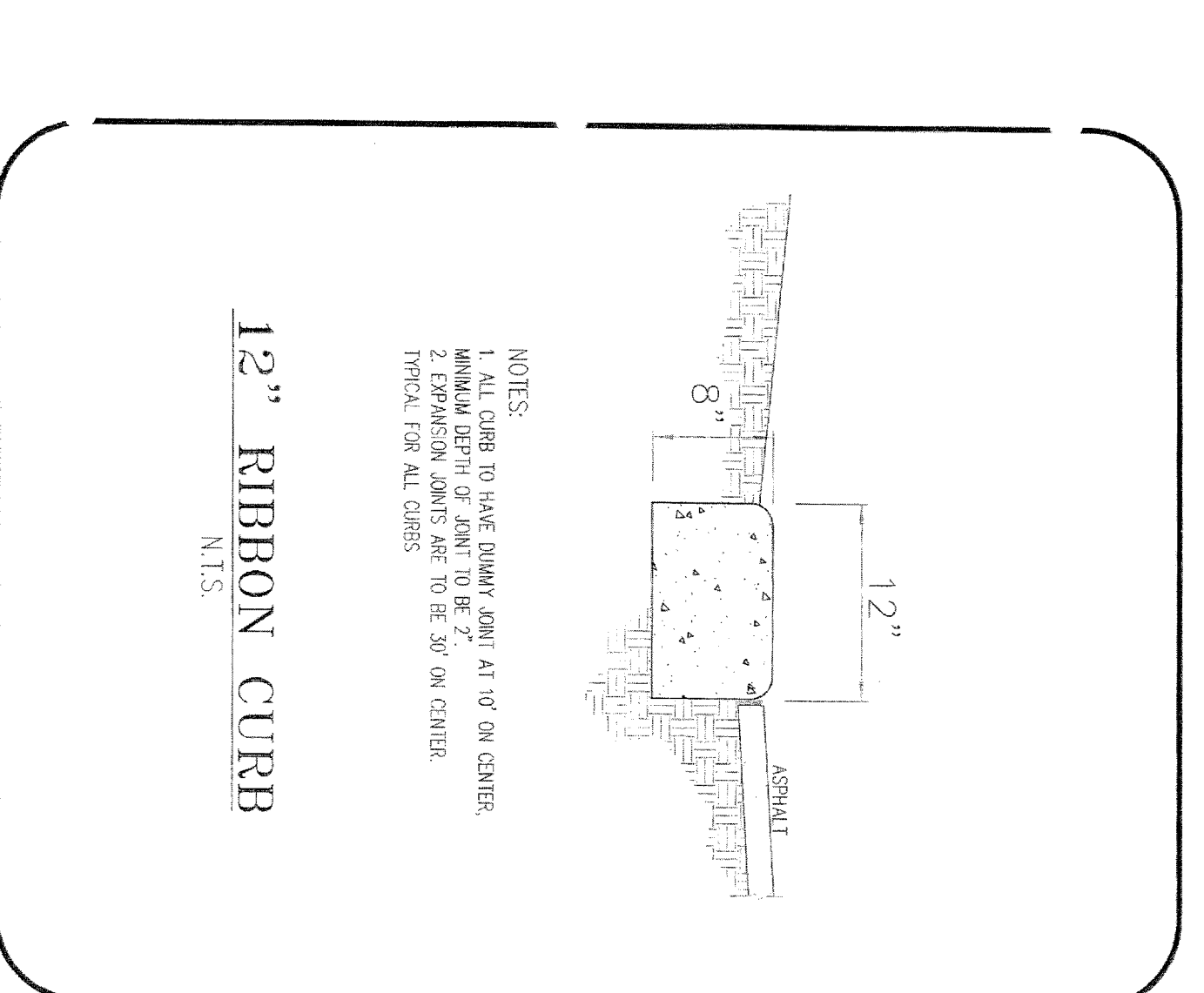

9 12\"/>

NOTE:
1. DETAIL REFLECTS HEAVY DUTY CONCRETE PAVING RECOMMENDATION BY PROJECT GEOTECHNICAL ENGINEER.
2. A TACK COAT SHALL BE APPLIED BETWEEN THE H/D SECTION AND THE ON-SITE ASPHALT SECTION.
3. JOINTS SHALL BE LOCATED AT NO LESS THAN 2' CENTERS. IF SAW CUTTING THE JOINTS IS STILL "GREEN" AND AS SOON AFTER PLACEMENT AS THE EQUIPMENT CAN BE MOVED ONTO THE PAVEMENT WITHOUT DISTURBING THE CONCRETE FINISH.

NOTES:
1) PROVIDE 1/2" TYP. FORWARD EXPANSION JOINTS (P.E.J.) AT MAX. OF 35' O.C. AND WHERE CONCRETE PAVING AND BACK OF CURB MEETS BUILDING, CONCRETE STEPS, COLUMNS, ETC.
2) PROVIDE C.J. AT 7' O.C.
3) ALL SIDEWALKS SHALL HAVE A CROSS SLOPE OF 1/4" INCH PER FT. UNLESS OTHERWISE INDICATED.
(FOR INTERNAL USE ONLY)

NOTES:
1. ALL CURBS TO HAVE DOWNY SLOPE AT TOP OF CURB.
2. EXPANSION JOINTS ARE TO BE 3/4" IN CENTER.
TYPICAL FOR ALL CURBS.