

1 Storefront Head / Jamb / Sill Details
 Scale 3"=1'-0"

2 NOT USED

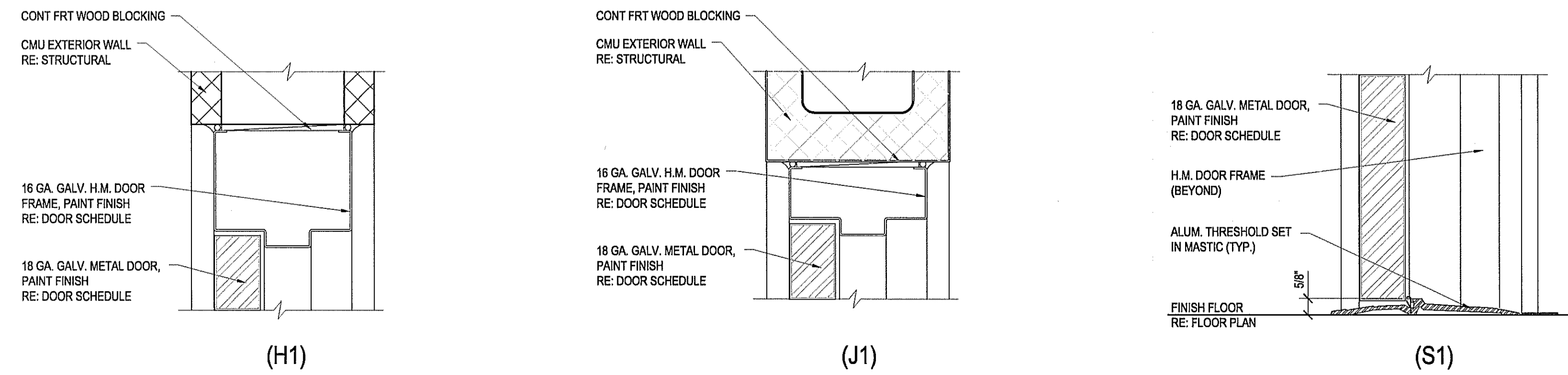

3 Hollow Metal Door Head / Jamb / Sill Details
 Scale 3"=1'-0"

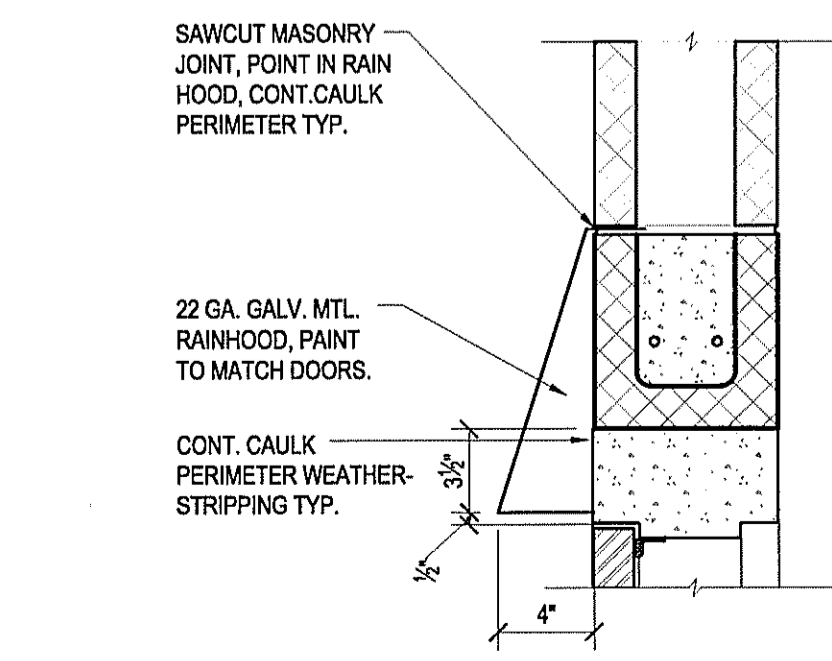

4 Rainhood Detail
 Scale 1 1/2"=1'-0"

Cuhaci & Peterson
 Architects Engineers Planners
 Florida Corporate Certificate #AA C000526
 1025 Prospect Avenue, Orlando, FL 32814
 Ph: 407.661.9100 Fax: 407.661.9101
 www.csp.com

Weingarten Realty Investors, Inc.
 CLIENT NAME
 2720 E. Colonial Drive
 Orlando, FL 32803

Outparcel 5 @ Palm Coast Landing
 PROJECT NAME
 N.E.C. SR-100 and Belle Terre Parkway
 Palm Coast, Florida

Door & Storefront Details
 SHEET TITLE

PROJECT NO. 208950	DATE 08/28/08	DRAWN CMM	CHECKED JF
RELEASE			
GREGORY SIMPSON FL # 6852			

A602